

Data sheet for SIMOTICS S-1FK7



Figure similar

MLFB-Ordering data

1FK7086-4CF71-1PB0

Client order no. :

Order no. :

Offer no. :

Remarks :

Item no. :

Consignment no. :

Project :

Engineering data

Rated speed (100 K) 3000 rpm

Number of poles 8

Rated torque (100 K) 6.5 Nm

Rated current 5.7 A

Static torque (60 K) 23.00 Nm

Static torque (100 K) 28.00 Nm

Stall current (60 K) 17.40 A

Stall current (100 K) 21.50 A

Moment of inertia 25.000 kgcm²

Efficiency 93.0 %

Physical constants

Torque constant 1.30 Nm/A

Voltage constant at 20° C 84.5 V/1000*min⁻¹

Winding resistance at 20° C 0.12 Ω

Rotating field inductance 3.1 mH

Electrical time constant 26.50 ms

Mechanical time constant 0.46 ms

Thermal time constant 65 min

Shaft torsional stiffness 63000 Nm/rad

Net weight of the motor 26.0 kg

Mechanical data

Motor type Permanent-magnet synchronous motor

Motor type High Dynamic

Shaft height 80

Cooling Natural cooling

Radial runout tolerance 0.050 mm

Concentricity tolerance 0.10 mm

Axial runout tolerance 0.10 mm

Vibration severity grade Grade A

Connector size 1.5

Degree of protection IP64

Design acc. to Code I IM B5 (IM V1, IM V3)

Temperature monitoring Pt1000 temperature sensor

Electrical connectors Connectors for signals and power rotatable

Color of the housing Standard (Anthracite RAL 7016)

Holding brake with holding brake

Shaft end Feather key

Encoder system Resolver R14DQ: resolver 14 bits (resolution 16384, internal 2-pole)



Figure similar

MLFB-Ordering data

1FK7086-4CF71-1PB0

Optimum operating point

Optimum speed	2000 rpm
Optimum power	3.8 kW

Limiting data

Max. permissible speed (mech.)	6000 rpm
Max. permissible speed (inverter)	6000 rpm
Maximum torque	105.0 Nm
Maximum current	115.0 A

Holding brake

Holding brake version	Permanent-magnet brake
Holding torque	22.0 Nm
Power supply voltage	DC 24 V \pm 10 %
Coil current	0.9 A
Opening time	200 ms
Closing time	60 ms
Highest braking work	1400 J

Recommended Motor Module

Rated inverter current	30 A
Maximum inverter current	72 A
Maximum torque	79.30 Nm

Copyright © Siemens AG 2005
 Code-drawing do not make any manual changes

The reproduction or use of this document or its contents is not permitted without express written authority. Offenders will be liable for damages. All rights, including rights created by patent grant or registration of a utility model or design, are reserved.

Weitergabe sowie Vervielfältigung dieser Unterlage, Verwertung und Mitteilung ihres Inhalts nicht gestattet, soweit nicht ausdrücklich zugestanden. Zuwahlungen verpflichten zu Schadenersatz. Alle Rechte vorbehalten, insbesondere fuer den Fall der Patenterteilung oder Gk-Entragung.

Conflicto a titre de secret d'entreprise. Tous droits reserves. Confiado como secreto industrial. Nos reservamos todos los derechos Comunicado como secreto empresarial. Reservados todos os direitos

1 2 3 4 5 6 7 8

A

B

C

D

E

F

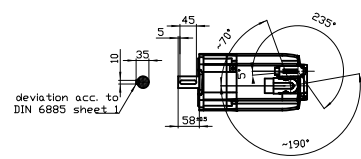
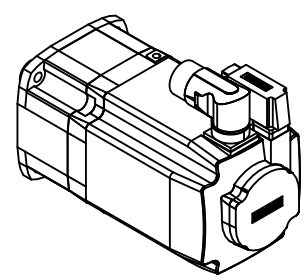
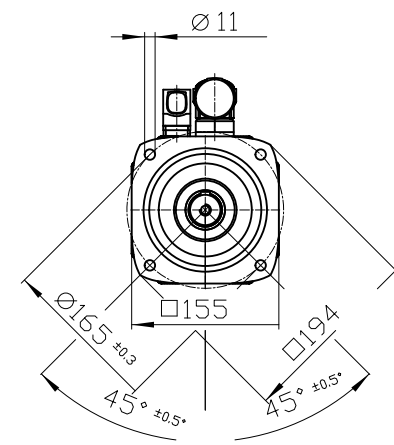
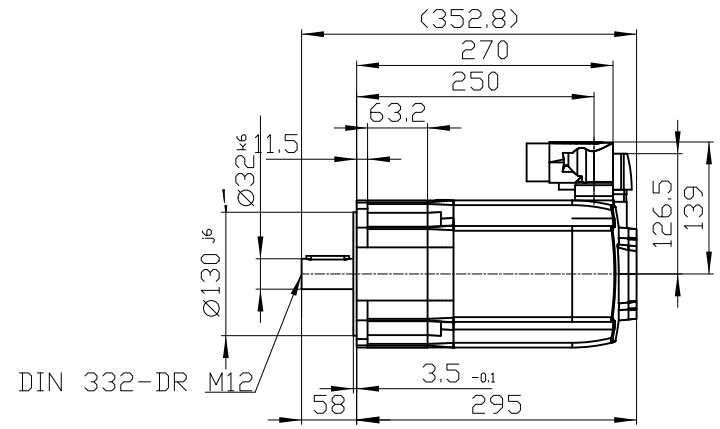
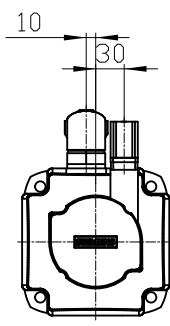

Connector size 1.5 = M40;
 6-pole for power and brake
 10-pole RJ45 socket

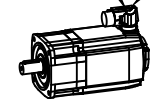

	-	
Unit	mm (in)	1FK7086-4CF71-1PB0
Date	4/13/23	
SIEMENS AG		-
-		DT

1 2 3 4 5 6 7 8

A

B

C

D

E

F